

The SHW 8 winch _

modular, flexible, powerful



You build the crane _ We build the hoist



- 1 The compact high performer SHW 8 has a height of lift of 28 m with 8/2 reeving and an S.W.L. of 160 t with 12/2 reeving.
- 2 There is a full range of heavy duty hoist motors suitable for long lifts.

The SHW 8 winch

- › **Field-proven in thousands of applications** _ using series components from the SH programme
- › **Maximum flexibility** _ ensured by modular construction
- › **High performance** _ versatile drive technology to meet demanding specifications
- › **Safe and cost-effective** _ thanks to plug and socket connections for electrical components
- › **Innovative** _ rope drive design results in compact overall headroom

Know-how

STAHL CraneSystems is among the leading hoist manufacturers in the world. The know-how acquired building quality machinery for more than 130 years ensures that the SHW 8 winch is built with the most up to date technology in mind. The main components, derived from our standard product line, are designed for lifting capacities up to 160t. The modular concept will enable us to not only meet our

Partnership

Moving materials expeditiously lowers cost, which consequently builds success and growth for you, the crane builders. STAHL CraneSystems delivers more than just hoisting equipment. We are willing to share with you as partners our acquired knowledge and experience, so together we can find the most effective solution for the material handling needs of your customers. Our offers for the winch include an extensive engineering package, including complete electrical drawings and instructions, and to scale CAD drawings that can be integrated into your crane design drawings.

customer's individual requirements, but also efficiently produce a high quality winch. The SHW 8 wire rope winch is the most up-to-date design available at present on the global market and is of course particularly low maintenance. Like all our products, the SHW 8 winch is also available -plosion protected for hazardous environments.

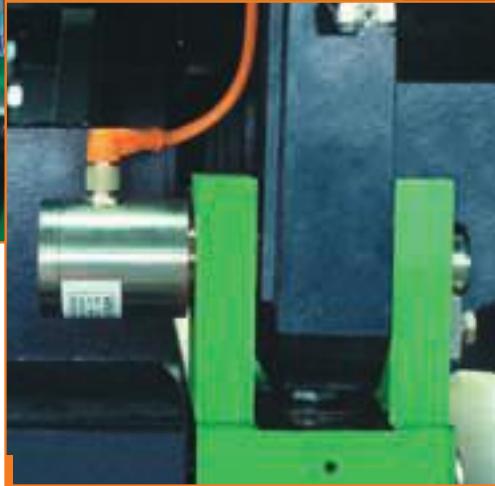

3

4

5

- 3 | Smooth trolley travel with soft starting characteristic.
- 4 | Depending on frame size, an overload device is used on the pivoted gear or at the rope anchorage. The load currently on the hook is recorded continuously.
- 5 | Shoe brake optional for motors up to 38 kW, standard on larger motors.

- › **Modular structure** _ Due to its modular construction, all components of the SHW 8 winch are bolted together. The components can be disassembled for shipment world wide and quickly reassembled at the job-site. Lifting lugs for assembly are provided. Once on site, the components are assembled in no time and the electrics connected up with plug and socket connections. The galvanized wire rope can be installed with minimum effort due to the double-reeved (true vertical lift) winch concept.
- › **Flexible drive technology** _ A variety of hoist motors is available: three motors, up to 38 kW with 1:6 ratio dual speeds, for economical solutions, and five motors, up to 98 kW with flux vector drive controls for precise operation with maximum control for the operator. Customer-specified speeds are available. All travel drives feature a smooth starting characteristic as standard. Powerful frequency inverters can also be supplied on request.
- › **Tried-and-tested standard components** _ Hoist motors, travel motors, hoist upper and lower geared limit switch, trolley endtrucks and galvanized wire rope derive from our standard product range, as does the overload cut-off device which is pre-adjusted in the factory.
- › **Plug-in electrics** _ Plug and socket connections for all electrical components apart from the hoist motor permit fast assembly on site and prevent mistakes in connection. Maintenance-friendly, components can be replaced without any problems if it should be necessary.
- › **Versatile options** _ Drum brake as additional holding brake, explosion protection, dual voltage motors, space heaters, maintenance platforms, dual hooks, load spectrum analyzer, large-format load display and load summation devices, travel limit switches and bottom block operated hoist limit switches are among the comprehensive standard options available.

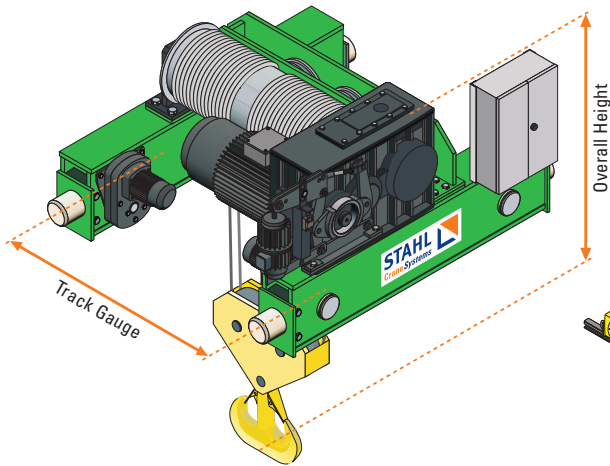

SHW8 winch

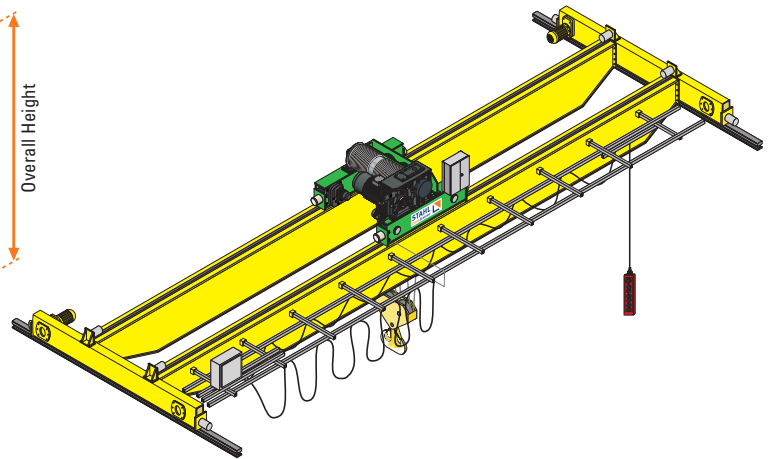

SHW8, installed on a double girder top running bridge crane

Excerpt from our standard production programme

Capacity [kg]	Duty Class*		Rope Reeving	Lifting Height* [m]	Track Gauge [mm]	Overall Height [mm]	Lift Speeds		Weight [kg]	
	FEM	ISO					dual up to [m/min]	variable up to [m/min]		
25,000	3 m	M6	4/2 - 1	26.0	2240	2039	1.3/8.0	1.0 - 20.0	6000	
				40.4	3150				6500	
				54.4	4000				7100	
32,000	2 m	M5		26.0	2240		2039	1.0/6.3	0.8 - 16	6000
				40.4	3150					6500
				54.4	4000					7100
40,000	1 Am	M4		26.0	2240		2039	0.8/5.0	0.63 - 12.5	6000
				40.4	3150					6500
				54.4	4000					7100
50,000	3 m	M6	8/2 - 1	13.0	2240	2274	0.6/4.0	0.5 - 10.0	7000	
				20.2	3150				7600	
				27.2	4000				8300	
63,000	2 m	M5		13.0	2240		2274	0.5/3.2	0.4 - 8.0	7000
				20.2	3150					7600
				27.2	4000					8300
80,000	1 Am	M4		13.0	2240		2274	0.4/2.5	0.32 - 6.3	7000
				20.2	3150					7600
				27.2	4000					8300
100,000	2 m	M5	12/2 - 1	9.6	2240	2852	0.3/1.8	0.25 - 4.9	12000	
				15.6	3150				12900	
				21.0	4000				13900	
125,000	1 Am	M4		9.6	2240		2852	0.24/1.4	0.2 - 4.0	12000
				15.6	3150					12900
				21.0	4000					13900
160,000	1 Bm	M3		8.2	2240		2937	0.2/1.2	0.15 - 3.1	12400
				13.5	3150					13400
				18.2	4000					14900

* Higher classifications and greater heights of lift possible on request.

➔ Ask for our Product Information SHW8 winch.

➔ www.stahlcranes.com

STAHL CraneSystems GmbH, Daimlerstr. 6, 74653 Künzelsau, Germany

Tel +49 7940 128-0, Fax +49 7940 55665, marketing@stahlcranes.com

